

MOVE THE WORLD FORWARD  MITSUBISHI
HEAVY
INDUSTRIES
GROUP

EDIA XL (4.0 - 5.5 TONS)



FB40-55(C)N(H) Series

ELECTRIC COUNTERBALANCE

WHEN
RELIABILITY IS
EVERYTHING...

 **MITSUBISHI**
FORKLIFT TRUCKS

QUIET AND STEADY FOR COMPLETE COMFORT AND CONTROL

The **EDiA XL** benefits from revolutionary features designed to give operators greater control than ever before. Electric differential lock provides optimum traction, and Four Wheel Steering ensures better grip and precision handling.

EDiA XL is also equipped with AutoBoost for extra speed and power when you need it most.

It is well known that if an operator is comfortable they will be more productive. **EDiA XL** features a rubber-sealed cabin that minimises micro-vibrations, and the overall noise level inside the cabin is just 65dB. **EDiA XL** also includes AC and heater options, so temperatures can be adjusted to suit the operator. These features combine to create a stress-free environment where the operator can focus on the task at hand.

For optimal handling, **EDiA XL** has dual joysticks that offer simultaneous lift and tilt functions, as well as Adaptive Lift Control (ALC) for added stability and little chassis movement when lowering loads.

EDiA XL has the power and performance to complete any task and overcome every challenge - making it the best alternative to an IC truck. **EDiA XL** is even proven to have the most efficient energy consumption in its class. So you keep going for longer, with zero emissions.





Easy charging latch

Small latch on the side of the truck allows charging cable to be connected without opening the battery door.

DRIVE

- **Sensitive Drive System (SDS)**
An intuitive driver-assist system for increased safety. Performance is managed according to steer angle and the velocity of foot and finger controls.
- **Intelligent Cornering System**
The truck senses the angle of a turn and reduces speed early for maximum stability and accurate, positive cornering.
- **ECO mode**
This mode optimises energy efficiency and gives smoother performance. Ideal for long shifts, training, new users, and part-time users.
- **PRO mode**
This mode maximises performance parameters, giving full control to more experienced operators in intensive situations.
- **AutoBoost***
Acceleration and torque boost functions provide more power when needed, such as on ramps.
- **Electric differential lock***
When activated, both front wheels spin simultaneously, giving the truck better traction and control in slippery conditions.



FORKS AND MAST

- **Strong, high-visibility mast**
Free-lift cylinder structure is optimised with hoses over chains for outstanding visibility.
- **Mechanical side shift with rollers**
Side shifter minimises static friction and reduces sway for better control.
- **Adjustable lifting and lowering setting**
Through the multi-functional configuration software Trucktool, the lifting and lowering functions can be adjusted.
- **Adaptive Lift Control (ALC)***
Allows truck to remain stable with fewer movements when lowering loads from high heights.
- **Passive Sway Control**
Minimises mast sway, especially in high lifts above 3m.

* AutoBoost, electric differential lock, and ALC are all in-house designed 'patent pending' features.

OPERATOR COMPARTMENT AND CONTROLS

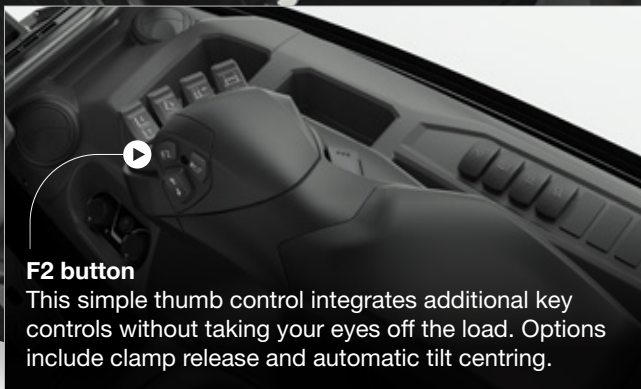

F2 button

This simple thumb control integrates additional key controls without taking your eyes off the load. Options include clamp release and automatic tilt centring.

- **Narrow inclined dashboard**

This enhances the driver's perception of surroundings - giving even greater visibility to the front and sides of the truck.

- **Spacious, open cabin**

The room means that operators of various sizes can benefit from a range of comfortable driving positions.

- **Comfortable cabin**

Rubber-mounted cabin reduces micro-vibrations and AC option allows operators to adjust temperatures, ensuring complete comfort throughout a shift. (Option)

- **Long handle bar**

Aids safer entry/exit.

- **Dashboard bar**

Easy to attach options such as monitors without blocking main display.



Flat floor

Extra-large low step

Entry and exit is easy and safe, thanks to a high-grip surface

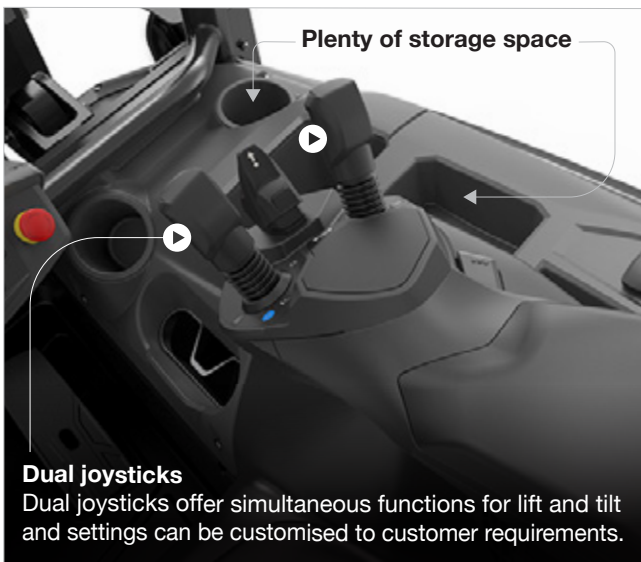

Plenty of storage space

Dual joysticks

Dual joysticks offer simultaneous functions for lift and tilt and settings can be customised to customer requirements.

- **Flat floor**

No obstructions and plenty of room for the operator.

- **Low Noise Lift**

Quietest hydraulic pump on the market contributes to low overall noise level (only 65dB).

- **Rear window**

Can be opened partially for ventilation or fully for emergency exit.

- **Four independently gliding windows**

Rear windows can glide to the front, this helps with situations such as accessing door controls while reversing

- **Low windshield wiper motor**

Operator has a good view from the middle of the mast.

- **Heater and/or Air Conditioner**

Operator can heat up or cool down the cabin as required. (Option)

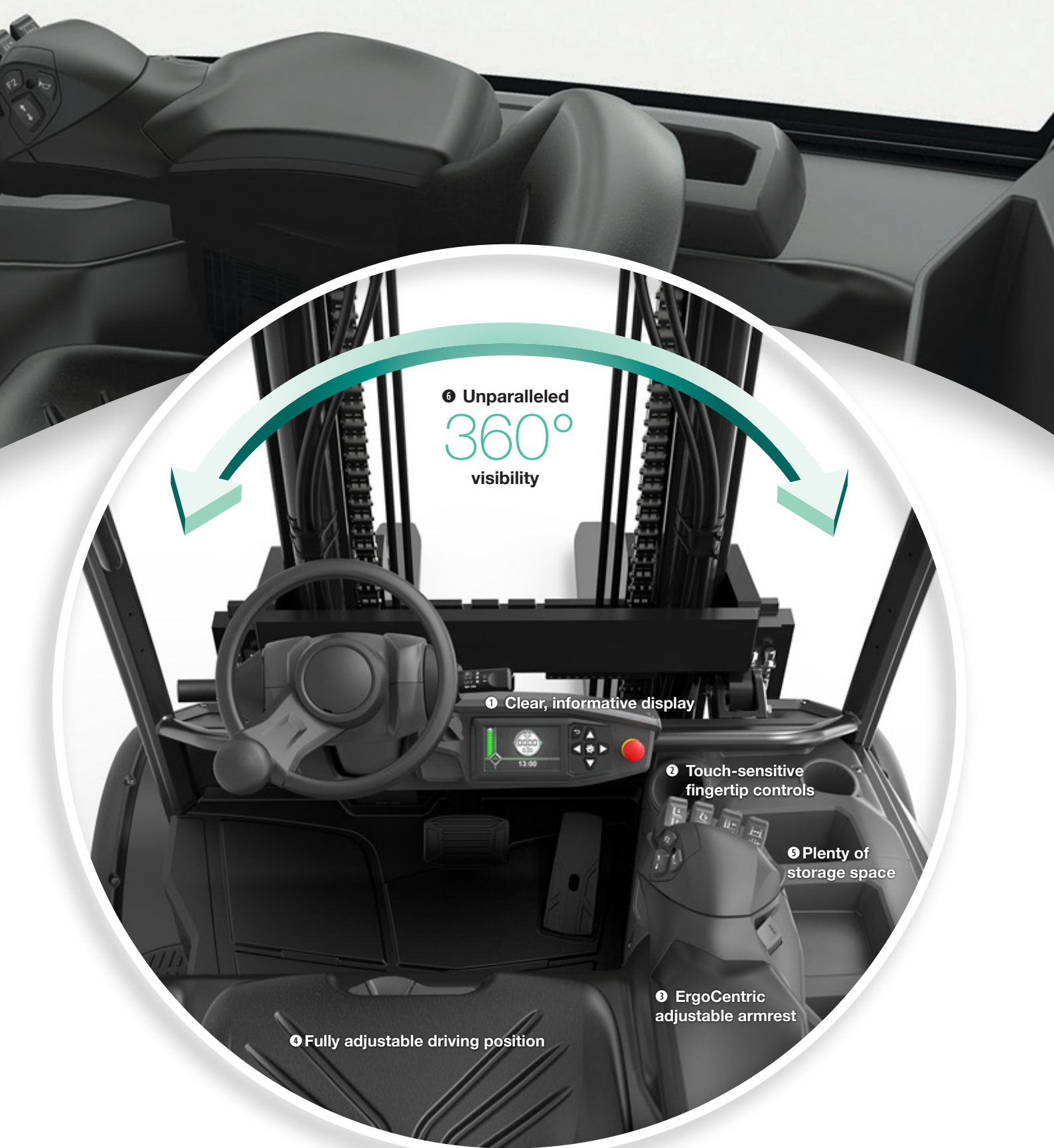

6 Unparalleled
360°
visibility

1 Clear, informative display

2 Touch-sensitive
fingertip controls

5 Plenty of
storage space

3 ErgoCentric
adjustable armrest

4 Fully adjustable driving position

1 Clear, informative display

Full colour and easy to read from all angles, even in direct sunlight. Perfectly positioned for at-a-glance reference, without reducing all-round visibility.

2 Touch-sensitive fingertip controls

Controls have a natural-feeling, spring-loaded response: press gently for finer control.

3 ErgoCentric adjustable armrest

This allows for a natural hand position, minimising injury and fatigue. Can be easily adjusted with one hand.

4 Fully adjustable driving position

Create the perfect seat, arm and steering wheel position for each operator's unique needs.

5 Plenty of storage space

Storage for on-board essentials, putting clipboard, mobile phone, drinks bottle and pen all easily to hand.

6 Unparalleled 360° visibility

An optimised mast, wheel, dashboard and counterweight design maximises visibility to load, forks, front and rear wheels - giving safe, confident operation in tight spaces.



FRAME AND BODY

- **EasyAccess battery compartment**
Battery door can be opened 180° for quick and easy battery checks, charging and changes.
- **Clear cabin entry**
Panels are curved to give optimum space for operators when entering/ exiting the truck.
- **Battery inspection hatch**
Operator seat can be tilted forward to give a quick and easy view of battery caps, so the battery does not need to be removed from the truck. (Option)



Low overhead guard
2220mm high for use
in and out of containers

Bright working lights

Lights on the mast structure illuminate the load and surrounding area for good visibility, without causing reflections on the cabin windows.



BRAKES

- **Sealed, wet-disc brakes**

Truck uses regenerative braking in normal driving, so mechanical brakes have a long life span and are virtually maintenance-free.

- **Automatic parking brake with hill hold**

The truck stops automatically when the accelerator is not engaged, preventing rolling on ramps. No need to remember to use a handle or switch.

Multiple regenerative functions recover waste energy

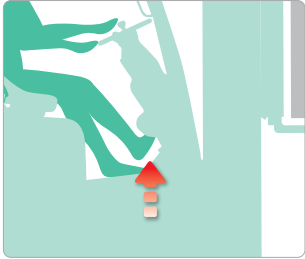

Coasting

Recovery when the foot is lifted off the accelerator.

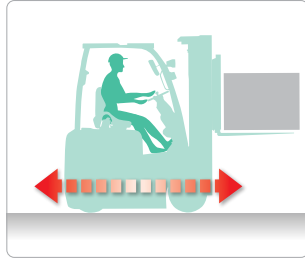

Plugging

Recovers when the direction changes.

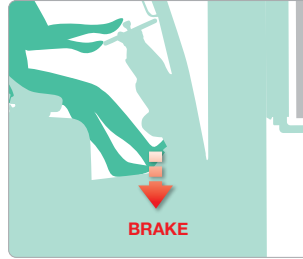

Braking

Recovers when the footbrake is engaged.

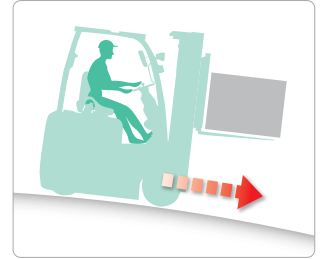

Speed suppression on Downslopes

Recovery when coasting downslope.

HYDRAULICS

- **High lift traction control**

Truck senses high lifts over 2.5m and automatically adapts load handling for steadier chassis movement.

- **Load sensing hydraulic system**

Load handling functions react similarly to different load weights.

STEERING SYSTEMS

- **Variable steering ratio**

Precision steering at high speeds with no need for overcorrections.

SYSTEMS

- **Emergency switch**

Weather-protected emergency switch stops the truck.

- **Sideways battery change**

Integrated sliding rollers offer quick and easy battery change for multi-shift operations. (Option).

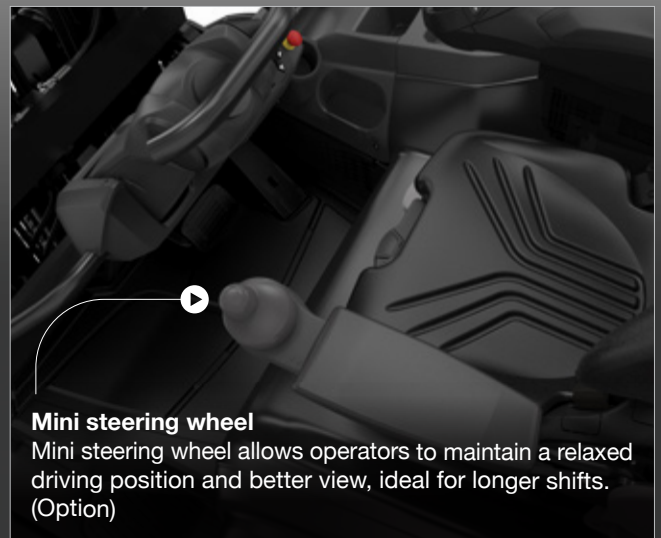

Mini steering wheel

Mini steering wheel allows operators to maintain a relaxed driving position and better view, ideal for longer shifts. (Option)

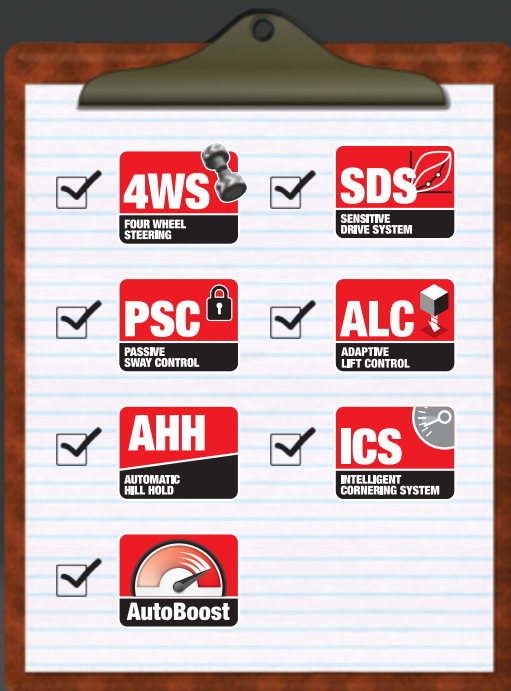

- **Four Wheel Steering (4WS)**

Front axle drive motors turn in separate directions for better grip and precise handling. The rear axle steers through a full 100°, with dual drive motors for instant, smooth turning on the spot and no initial "push". This offers excellent manoeuvrability in tight spaces.

- **Perfectly weighted steering**

Optimal steering wheel size with a light but firm feel gives confidence and manoeuvrability at all speeds.

STANDARD SPECIFICATIONS

CHARACTERISTICS						
1	Manufacturer (abbreviation)			Mitsubishi Forklift Trucks	Mitsubishi Forklift Trucks	Mitsubishi Forklift Trucks
2	Manufacturer's model designation			FB40N	FB45N	FB50CN
3	Power source: (battery, diesel, LP gas, petrol)			Battery	Battery	Battery
4	Operator type: pedestrian, (operator)-standing, -seated			Seated	Seated	Seated
5	Load capacity	Q	kg	4000	4500	4990
6	Load center distance	c	mm	500	500	500
7	Load distance, axle to fork face	x	mm	540	540	540
8	Wheelbase	y	mm	1946	1946	1946
WEIGHT						
9	Truck weight, without load / including battery (simplex mast, lowest lift height)		kg	7290	7648	7991
10	Axle loading with maximum load, front / rear (simplex mast, lowest lift height)		kg	10040 / 1250	10795 / 1353	11574 / 1417
11	Axle loading without load, front / rear (simplex mast, lowest lift height)		kg	3902 / 3388	3890 / 3758	3902 / 4089
WHEELS, DRIVE TRAIN						
12	Tyres: V=solid, L=pneumatic, SE=solid pneumatic - front / rear			SE	SE	SE
13	Tyre dimensions, front			250x15 (710)	250x15 (710)	355 / 50-15 (710)
14	Tyre dimensions, rear			7.00x12 (650)	7.00x12 (650)	7.00x12 (650)
15	Number of wheels, front / rear (x=driven)			2X / 2	2X / 2	2X / 2
16	Truck width (center of tyres), front	b10	mm	1143	1143	1154
17	Truck width (center of tyres), rear	b11	mm	1169	1169	1169
DIMENSIONS						
18	Mast tilt, forwards / backwards	α / β	$^{\circ}$	6 / 8	6 / 8	6 / 8
19	Height with mast lowered (see tables)	h1	mm	2420	2420	2420
20	Free lift (see tables)	h2	mm	150	150	150
21	Lift height (see tables)	h3	mm	3300	3300	3300
22	Overall height with mast raised	h4	mm	4205	4205	4205
23	Height to top of overhead guard	h6	mm	2340	2340	2340
24	Seat height	h7	mm	1320	1320	1320
25	Tow coupling height	h10	mm	675	675	675
26	Overall length	l1	mm	4025	4025	4025
27	Length to fork face (includes fork thickness)	l2	mm	2825	2825	2825
28	Overall width	b1/b2	mm	1370	1370	1450
29	Fork dimensions (thickness, width, length)	s / e / l	mm	50 / 150 / 1200	50 / 150 / 1200	50 / 150 / 1200
30	Fork carriage to DIN 15 173 A/B/no			3A	3A	3A
31	Fork carriage width	b3	mm	1190	1190	1190
32	Ground clearance under mast, with load	m1	mm	150	150	150
33	Ground clearance at center of wheelbase, with load (forks lowered)	m2	mm	150	150	150
34	Working aisle width with 1000 x 1200 mm pallets, crosswise	Ast	mm	4125	4125	4125
35	Working aisle width with 800 x 1200 mm pallets, crosswise	Ast	mm	3938	3938	3938
36	Working aisle width with 800 x 1200 mm pallets, lengthwise	Ast	mm	4264	4264	4264
37	Turning circle radius	Wa	mm	2289	2289	2289
38	Minimum distance between centers of rotation	b13	mm	49	49	49
PERFORMANCE						
39	Travel speed, with / without load		km/h	18 / 20	18 / 20	18 / 20
40	Lifting speed, with / without load		m/s	0.41 / 0.53	0.38 / 0.53	0.35 / 0.53
41	Lowering speed, with / without load		m/s	0.53 / 0.51	0.52 / 0.51	0.52 / 0.51
42	Rated drawbar pull, with / without load		N	16000 / 16400	16800 / 17700	16800 / 17700
43	Maximum drawbar pull, with / without load (5 min short duty)		N	17300 / 18400	17300 / 18400	17300 / 18400
44	Gradeability, with / without load		%	15 / 23	15 / 23	14 / 22
45	Maximum gradeability, with / without load		%	15.8 / 26.6	15.6 / 23.7	14.6 / 22.6
46	Acceleration time (10 metres) with / without load		s	4.6 / 3.9	4.7 / 3.9	4.8 / 4.0
47	Service brakes (mechanical / hydraulic / electric / pneumatic)			Hydraulic	Hydraulic	Hydraulic
ELECTRIC MOTORS						
48	Drive motor capacity (60 min. short duty)		kW	2x16	2x16	2x16
49	Lift motor output at 15% duty factor		kW	34	34	34
50	Battery to DIN 43 531 / 35 / 36 A/B/C/no			DIN 43 536/A	DIN 43 536/A	DIN 43 536/A
51	Battery voltage/capacity at 5-hour discharge		V/Ah	80 / 775	80 / 775	80 / 775
52	Battery weight		kg	1863	1863	1863
53	Energy consumption according to DIN EN 16796		kWh/h	10.2 ¹⁾	10.6 ¹⁾	11.0 ¹⁾
MISCELLANEOUS						
54	Type of drive control			AC	AC	AC
55	Maximum operating pressure for attachments		bar	210	210	210
56	Oil flow for attachments		l/min	45	45	45
57	Noise level, value at operator's ear (EN 12053)		dB(A)	65	65	65
58	Towing coupling design / DIN type, ref.			15 170	15 170	15 170

1) Measured with 60 cycles test

2) Measured with 45 cycles test

FB40-55(C)N(H) Series

Mitsubishi Forklift Trucks	Mitsubishi Forklift Trucks	Mitsubishi Forklift Trucks
FB50N	FB50NH	FB55NH
Battery	Battery	Battery
Seated	Seated	Seated
4990	5000	5500
500	600	600
540	560	560
2090	2090	2090
8347	8472	8711
11563 / 1784	12009 / 1463	12799 / 1412
4075 / 4272	4234 / 4238	4246 / 4465
SE	SE	SE
355 / 50-15 (710)	355 / 50-15 (710)	355 / 50-15 (710)
7.00x12 (650)	7.00x12 (650)	7.00x12 (650)
2X / 2	2X / 2	2X / 2
1154	1154	1154
1169	1169	1169
6/8	6/8	6/8
2420	2420	2420
150	160	160
3300	3300	3300
4205	4345	4345
2340	2340	2340
1320	1320	1320
675	675	675
4170	4190	4190
2970	2990	2990
1450	1450	1450
50 / 150 / 1200	60 / 150 / 1200	60 / 150 / 1200
3A	4A	4A
1190	1190	1190
150	150	150
150	150	150
4273	4291	4291
4086	4104	4104
4412	4439	4439
2434	2434	2434
49	49	49
18 / 20	18 / 20	18 / 20
0.35 / 0.53	0.35 / 0.53	0.32 / 0.53
0.52 / 0.51	0.52 / 0.51	0.51 / 0.51
17600 / 18100	17500 / 17700	17600 / 18000
21500 / 22600	21500 / 22600	21500 / 22600
14 / 22	13.5 / 21.5	13 / 21
16.6 / 28.7	16.5 / 28.2	16.4 / 27.3
4.6 / 4.1	4.7 / 4.1	4.8 / 4.1
Hydraulic	Hydraulic	Hydraulic
2x16	2x16	2x16
34	34	34
DIN 43 536/A	DIN 43 536/A	DIN 43 536/A
80 / 930	80 / 930	80 / 930
2178	2178	2178
11.2 ¹⁾	7.8 ²⁾	8.2 ²⁾
AC	AC	AC
210	210	210
45	45	45
65	65	65
15 170	15 170	15 170

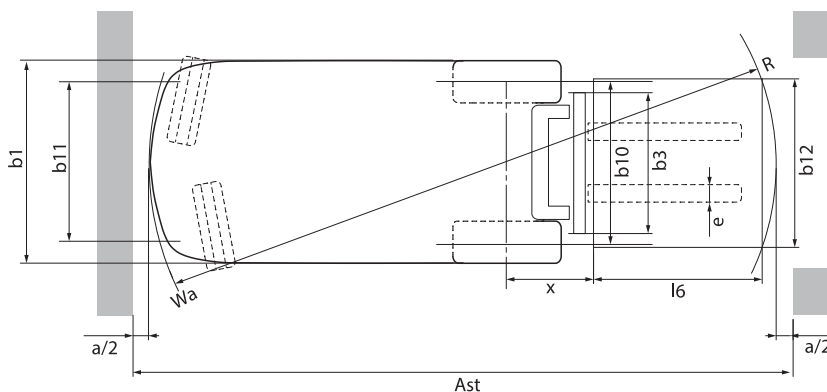
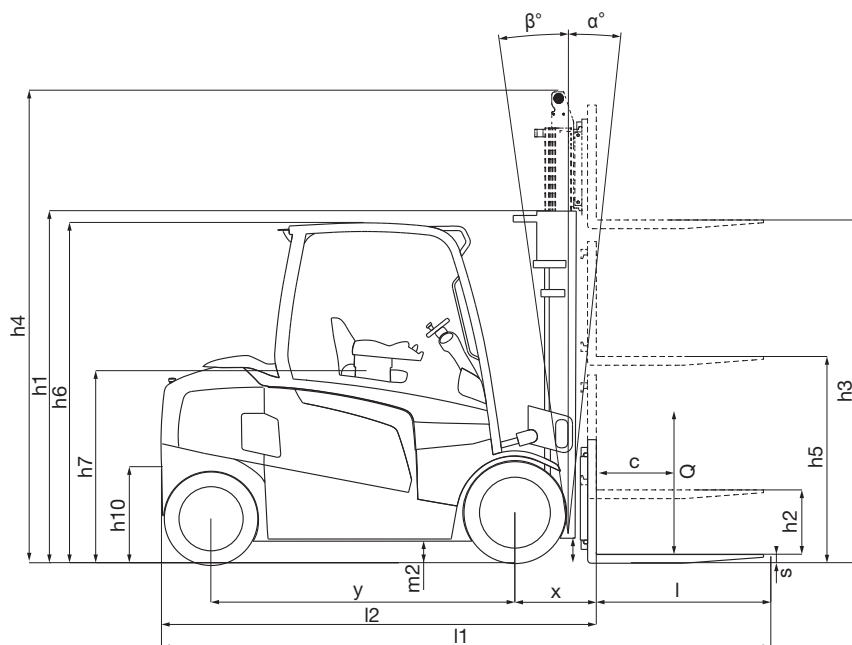

$A_{st} = W_a + R + a$
 A_{st} = Working aisle width with load
 W_a = Turning radius
 a = Safety clearance = 2 x 100mm
 $R = \sqrt{(l_6 + x)^2 + (b_{12} / 2 - b_{13})^2}$
 b_{12} = Pallet width (1200mm)



- h1 Height with mast lowered
- h2 Standard free lift
- h3 Lift height
- h4 Height with mast raised
- h5 Full free lift
- Q Lifting capacity, rated load
- c Load centre (distance)

STANDARD EQUIPMENT & OPTIONS

● = Standard ▲ = Option

	FB40N	FB45N	FB50CN	FB50N	FB50NH	FB55NH
GENERAL						
4-wheel chassis, 80 volts, front wheel dual drive	●	●	●	●	●	●
Key pre-set economy or high performance mode (ECO / PRO)	●	●	●	●	●	●
3-valve hydraulic fingertip control mounted on an ergonomic armrest	●	●	●	●	●	●
Variable hydraulic speed control functions	●	●	●	●	●	●
Battery compartment side door	●	●	●	●	●	●
Multifunctional interactive full colour display	●	●	●	●	●	●
Intelligent curve control	●	●	●	●	●	●
Tiltable steering column	●	●	●	●	●	●
TruckTool setup and diagnostics	●	●	●	●	●	●
IPS (Seat Switch Timeout = all functions are disabled, the truck will go into the stop mode, automatically applied parking brake)	●	●	●	●	●	●
Full-suspension vinyl Grammer MSG65 seat	●	●	●	●	●	●
CE name plates -language markings	●	●	●	●	●	●
Operations and Maintenance Manual	●	●	●	●	●	●
DIN battery connectors on frame	●	●	●	●	●	●
Back-up drive horn button	●	●	●	●	●	●
Battery door detection sensor	●	●	●	●	●	●
Fingertip control armrest	●	●	●	●	●	●
Manual control levers	▲	▲	▲	▲	▲	▲
Dual Joystick	▲	▲	▲	▲	▲	▲
Mini steering wheel	▲	▲	▲	▲	▲	▲
Air conditioner	▲	▲	▲	▲	▲	▲
Heater	▲	▲	▲	▲	▲	▲
POWER SOURCE						
Lead acid battery	▲	▲	▲	▲	▲	▲
FRAME						
Battery sideways exchange chassis	▲	▲	▲	▲	▲	▲
Battery roller bed	●	●	●	●	●	●
Battery tray	▲	▲	▲	▲	▲	▲
Battery sideways exchange tool	▲	▲	▲	▲	▲	▲
Battery inspection hatch	▲	▲	▲	▲	▲	▲
Easy charging	▲	▲	▲	▲	▲	▲
T-bar battery stand	▲	▲	▲	▲	▲	▲
LIGHTING						
LED work lights	●	●	●	●	●	●
Red side lines	▲	▲	▲	▲	▲	▲
Amber strobe	▲	▲	▲	▲	▲	▲
Amber strobe mounted low	▲	▲	▲	▲	▲	▲
“Blue point” rear light	▲	▲	▲	▲	▲	▲
“Blue point” rear light mounted low	▲	▲	▲	▲	▲	▲
ELECTRICAL SYSTEM						
Smart backup alarm	▲	▲	▲	▲	▲	▲
Current output	▲	▲	▲	▲	▲	▲
12V connector	▲	▲	▲	▲	▲	▲
Operator presence pedal	▲	▲	▲	▲	▲	▲
Electronic differential lock	▲	▲	▲	▲	▲	▲
Dual pedal layout	▲	▲	▲	▲	▲	▲
Drive direction selection switch on ergonomic armrest (Forward-Backward) *Only on FC controls	●	●	●	●	●	●
Drive direction lever in steering column (Forward-Neutral-Reverse)	▲	▲	▲	▲	▲	▲
Road light kit	▲	▲	▲	▲	▲	▲
PIN code access with start switch	▲	▲	▲	▲	▲	▲
Automated lift controls	●	●	●	●	●	●
Automatic tilt centering via the F2 button with FC TILT/C	▲	▲	▲	▲	▲	▲
Load weight indicator	▲	▲	▲	▲	▲	▲

	FB40N	FB45N	FB50CN	FB50N	FB50NH	FB55NH
OPERATOR'S CABIN						
Grammer MSG65 seat	●	●	●	●	●	●
Grammer MSG65 with heater	▲	▲	▲	▲	▲	▲
Grammer MSG65 with cloth upholstery	▲	▲	▲	▲	▲	▲
Grammer MSG65 with cloth upholstery and heater	▲	▲	▲	▲	▲	▲
Grammer MSG75	▲	▲	▲	▲	▲	▲
Grammer MSG75 with heater	▲	▲	▲	▲	▲	▲
Grammer MSG75 with cloth upholstery	▲	▲	▲	▲	▲	▲
Grammer MSG75 with cloth upholstery and heater	▲	▲	▲	▲	▲	▲
Backrest extension	●	●	●	●	●	●
ACCESSORIES						
Rear view mirror	▲	▲	▲	▲	▲	▲
External rear view mirror	▲	▲	▲	▲	▲	▲
Dead angle mirror	▲	▲	▲	▲	▲	▲
Wide view mirror	▲	▲	▲	▲	▲	▲
A4 size paper holder	▲	▲	▲	▲	▲	▲
Camera	▲	▲	▲	▲	▲	▲
Accessory clamp	▲	▲	▲	▲	▲	▲
Fire extinguisher	▲	▲	▲	▲	▲	▲
CABIN						
Default OHG	●	●	●	●	●	●
Low OHG	▲	▲	▲	▲	▲	▲
Battery Inspection OHG	▲	▲	▲	▲	▲	▲
Front screen and roof with wiper / washer	▲	▲	▲	▲	▲	▲
Low front screen and roof with wiper / washer	▲	▲	▲	▲	▲	▲
Front screen and roof with wiper / washer with battery inspection	▲	▲	▲	▲	▲	▲
Safety doors	▲	▲	▲	▲	▲	▲
Delux cabin	▲	▲	▲	▲	▲	▲
EXTERIOR						
Special colour (RAL) for the frame and counterweight	▲	▲	▲	▲	▲	▲
FORKS & CARRIAGE						
Various fork lengths (1000 - 2400mm) as well as fork deletion	▲	▲	▲	▲	▲	▲
Side shifter W1190mm	▲	▲	▲	▲	▲	▲
Integrated side shifter W1190mm	▲	▲	▲	▲	▲	▲
Fork positioner+ integrated side shifter	▲	▲	▲	▲	▲	▲
Load backrest	●	●	●	●	●	●
HYDRAULIC SYSTEM						
3/4/5-way valve armrest-mounted fingertip control	▲	▲	▲	▲	▲	▲
3/4-way valve manual control	▲	▲	▲	▲	▲	▲
Lift Control	●	●	●	●	●	●
Double action FC 3 v, for clamp usage	▲	▲	▲	▲	▲	▲
Double action FC 4 v, for clamp usage	▲	▲	▲	▲	▲	▲
Double action MC 3 v, for clamp usage	▲	▲	▲	▲	▲	▲
Double action MC 4 v, for clamp usage	▲	▲	▲	▲	▲	▲
Hydraulic accumulator	▲	▲	▲	▲	▲	▲
Food grade hydraulic oil	▲	▲	▲	▲	▲	▲
Biodegradable hydraulic oil	▲	▲	▲	▲	▲	▲
Cold area hydraulic oil VG15	▲	▲	▲	▲	▲	▲
Hot area hydraulic oil VG46	▲	▲	▲	▲	▲	▲
TYRES						
Solid Pneumatic Tyres	●	●	●	●	●	●
Pneumatic Tyres	▲	▲	▲	▲	▲	▲
Non-marking Solid Tyres	▲	▲	▲	▲	▲	▲
Cushion tyres	▲	▲	▲	▲	▲	▲
Solid Pneumatic Twin Tyres	▲	▲	▲	▲	▲	▲

Like any product bearing the "MITSUBISHI" name our materials handling equipment benefits from the tremendous heritage, huge resources and cutting-edge technology of one of the world's largest corporations – Mitsubishi Heavy Industries Group.

Engineering spacecraft, jet planes, power plants and more, MHI specialises in those technologies where performance, dependability and superiority decide your success or failure...

So when we promise you quality, reliability and value for money, you know it's a guarantee we have the power to deliver.

That's why every model in our award-winning and comprehensive range of lift trucks and warehouse equipment is built to a high specification – to ensure it keeps working for you. Day after day. Year after year. Whatever the job. Whatever the conditions.

YOU'LL NEVER WORK ALONE

As your local authorised dealer, we are here to keep your trucks working – through our extensive experience, our technical excellence and our commitment to customer care.

We are your local experts, backed by efficient channels to the entire organisation of Mitsubishi Forklift Trucks.

No matter where you are, we are close by – with the capability to meet your needs.

Discover how Mitsubishi Forklift Trucks give you more from your local authorised dealer or when you visit our website www.mitforklift.com.sg

Performance specifications may vary depending on standard manufacturing tolerances, vehicle condition, types of tyres, floor or surface conditions, applications or operating environment. Trucks may be shown with non-standard options. Specific performance requirements and locally available configurations should be discussed with your distributor of Mitsubishi forklift trucks. We follow a policy of continual product improvement. For this reason, some materials, options and specifications could change without notice.

© 2021 by MLAP. All Rights Reserved. All registered trademarks are the property of their respective owners. Printed in Singapore.

FMIT0181(07-2021)

