



# PBV20EA / PBV20EAH / PBV25EA / PBV30EA

Electric Rider 2.0 / 2.5 / 3.0t

---

# PBV20EA/PBV20EAH/PBV25EA/ PBV30EA

Electric Rider 2.0 / 2.5 / 3.0t

Distinguishing mark										
1.1	Model designation		PBV20EA	PBV20EAH	PBV25EA	PBV30EA				
1.2	Drive unit		Electrics	Electrics	Electrics	Electrics				
1.3	Operation type		standing	standing	standing	standing				
1.4	rated capacity	Q	kg	2000	2000	2500	3000			
1.5	Load center distance	c	mm	600	600	600	600			
1.6	Load distance	x	mm	916/982   937/1003	916/982   937/1003	916/982   937/1003	916/982   937/1003			
1.7	Wheelbase	y	mm	1418   1438	1418   1438	1418   1438	1418   1438			
Weight										
2.1	Service weight (include battery)		kg	670	690	690	690			
2.2	Axle loading, laden driving side/loading side		kg	1066 / 1604	1076 / 1614	1176 / 2014	1356 / 2334			
2.3	Axle loading, unladen driving side/loading side		kg	546 / 124	556 / 134	556 / 134	556 / 134			
Type, Chassis										
3.1	Tyre type driving wheels/loading wheels			polyurethane/polyurethane	polyurethane/polyurethane	polyurethane/polyurethane	polyurethane/polyurethane			
3.2	Tyre size, driving wheels (diameter*width)		mm	Φ230x75	Φ230x75	Φ230x75	Φ230x75			
3.3	Tyre size, loading wheels (diameter*width)		mm	Φ85x70 / Φ83x115	Φ85x70 / Φ83x115	Φ85x70 / Φ83x115	Φ85x70 / Φ83x115			
3.4	Tyre size, caster wheels (diameter*width)		mm	Φ130x60	Φ130x60	Φ130x60	Φ130x60			
3.5	Wheels, number driving, caster/loading (x=drive wheels)		mm	1x2/4 / 1x2/2	1x2/4 / 1x2/2	1x2/4 / 1x2/2	1x2/4 / 1x2/2			
3.6	Track width, front, driving side	b <sub>10</sub>	mm	510	510	510	510			
3.7	Track width, rear, loading side	b <sub>11</sub>	mm	370/430/515	370/430/515	370/430/515	370/430/515			
Dimensions										
4.1	Lift height	h <sub>3</sub>	mm	125	125	125	125			
4.2	Height drawbar in driving position min./max	h <sub>14</sub>	mm	1150 / 1470	1150 / 1470	1150 / 1470	1150 / 1470			
4.3	Lowered height	h <sub>13</sub>	mm	85	85	85	85			
4.4	Overall length	l <sub>1</sub>	mm	1860   1930	1860   1930	1860   1930	1860   1930			
4.5	Length to face of forks	l <sub>2</sub>	mm	710	710	710	710			
4.6	Overall width	b <sub>1</sub> /b <sub>2</sub>	mm	730	730	730	730			
4.7	Fork dimensions	s/ e/ l	mm	55/170/1150   55/170/1220	55/170/1150   55/170/1220	55/170/1150   55/170/1220	55/170/1150   55/170/1220			
4.8	Distance between fork-arms	b <sub>5</sub>	mm	540 / 600 / 685	540 / 600 / 685	540 / 600 / 685	540 / 600 / 685			
4.9	Ground clearance, center of wheelbase	m <sub>2</sub>	mm	30	30	30	30			
4.10	Aisle width for pallets 1000 x 1200 crossways	Ast	mm	2522	2522	2522	2522			
4.11	Aisle width for pallets 800 x 1200 lengthways	Ast	mm	2370	2370	2370	2370			
4.12	Turning radius	Wa	mm	1700	1700	1700	1700			
Performance data										
5.1	Travel speed, laden/unladen	km/h	km/h	5.5 / 6	9.0 / 12.0	5.5 / 6	5.5 / 6			
5.2	Lifting speed, laden / unladen	m / s		0.023 / 0.031	0.023 / 0.031	0.023 / 0.031	0.021 / 0.031			
5.3	Lowering speed, laden / unladen	m / s		0.043 / 0.032	0.043 / 0.032	0.043 / 0.032	0.048 / 0.032			
5.4	Max. gradeability, laden / unladen	%		8 / 16	8 / 16	6 / 16	5 / 16			
5.5	Service brake type			Electromagnetic	Electromagnetic	Electromagnetic	Electromagnetic			
Electric-engine										
6.1	Drive motor rating S2 60min	kW		1.5	2.5	1.5	2.5			
6.2	Lift motor rating at S3 15%	kW		2.2	2.2	2.2	2.2			
6.3	The maximum allowed size battery	mm		660 x 205 x 660	660 x 205 x 660	660 x 205 x 660	660 x 205 x 660			
6.4	Battery voltage / nominal capacity K5	V/Ah		24 / 210	24 / 210	24 / 210	24 / 210			
6.5	Battery weight	kg		190	190	190	190			
Additional data										
7.1	Type of drive control			AC	AC	AC	AC			
7.2	Steering type			Mechanical / Electronic	Electronic	Mechanical / Electronic	Electronic			
7.3	Sound pressure level at the driver's ear	dB(A)		74	74	74	74			

Note: The truck maximum operating hours per charge is dependent on the nature of tasks assigned. For more information on the truck functionality, features, and other customization options, please contact your nearest dealership for assistance. Improvement made to truck may result in changes to the truck parameters.

- The parameters in the table are of the standard model. For more information, please contact us.
- The parameters are subject to change without notice.



# Grab the **TOUGHEST** Feel the **RUSH**

Designed to handle loads and shuttle over long distances, the PBV-EA series is the right fit to manage most material handling tasks efficiently and speedily without much delays.

Ranging from 2.0T to 3.0T, the PBV-EA series is capable of not just handling one load, it can also **handle up to TWO loads** at one go with the use of longer forks option that can travel up to a **maximum speed of 12km/hr!**

The PBV-EA is equipped with a standard **foldable platform with full suspension** provide a good sense of comfort while operating on the truck over a span period. The usage of a **standard electric power steering** has further enhanced the overall ride experience that facilitates smooth and effortless control while the **foldable sideguards** provide additional assurance to keep the operator safe at all times!



## ✓ **24/7 Secured**

- Exclusive pin-code entry limits any unauthorized usage of the truck

## ✓ **High Performance AC drive system**

- Smooth travel speed control up to \*12km/hr
- Competitive and powerful rated AC drive motor allows the truck to overcome most terrains with ease
- \*Only applicable to high-performance model PBV20EAH

## ✓ **Quick Battery Change**

- Top access to the battery for easy monitoring of the battery water level
- Optional side battery change system facilitates safer battery change procedures

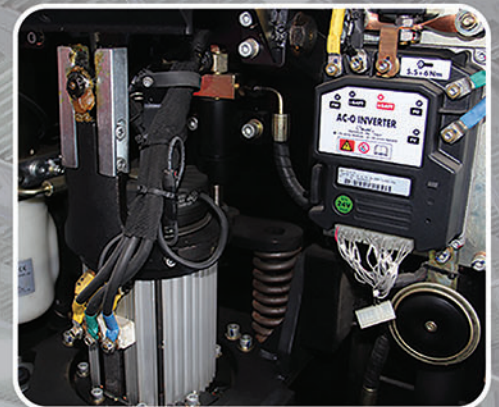

## ✓ **Vivid Digital Display & Controls**

- Standard LED indicators displays Battery level, On/Off status, Running Hours and Fault Code
- Multifunctional electronic control handle to facilitate quick controls
- Creep speed mode automatically reduce the truck travel speed when the tiller arm is tilted at near neutral position
- Low voltage protection system automatically limit travel speed to indicate immediate charging of the truck when the battery level hits 20% or below

## ✓ **Easy Maintenance and Serviceability**

- Hassel free access to the internal key components for quick inspection, maintenance, and replacement works
- Adjustable forks linkages to ensure smooth lifting of the forks
- Quick plug-in fault diagnostics feature
- IP54 ZAPI AC controller offers better protection against water & dust ingression
- High-quality AMP connectors and durable electrical harnesses



## ✓ **Safe Operating**

- Sideguards and platform limit switches ensure safe operating procedures to be well observed by the operator
- Reverse belly button changes the traveling direction immediately upon contact helps to protect the operator from any imminent impact
- Full electromagnetic brakes with anti-rollback function
- Standard full suspension standing platform for comfortable ride experience
- Low bottom frame design keeps the operator foot out of the undercarriage



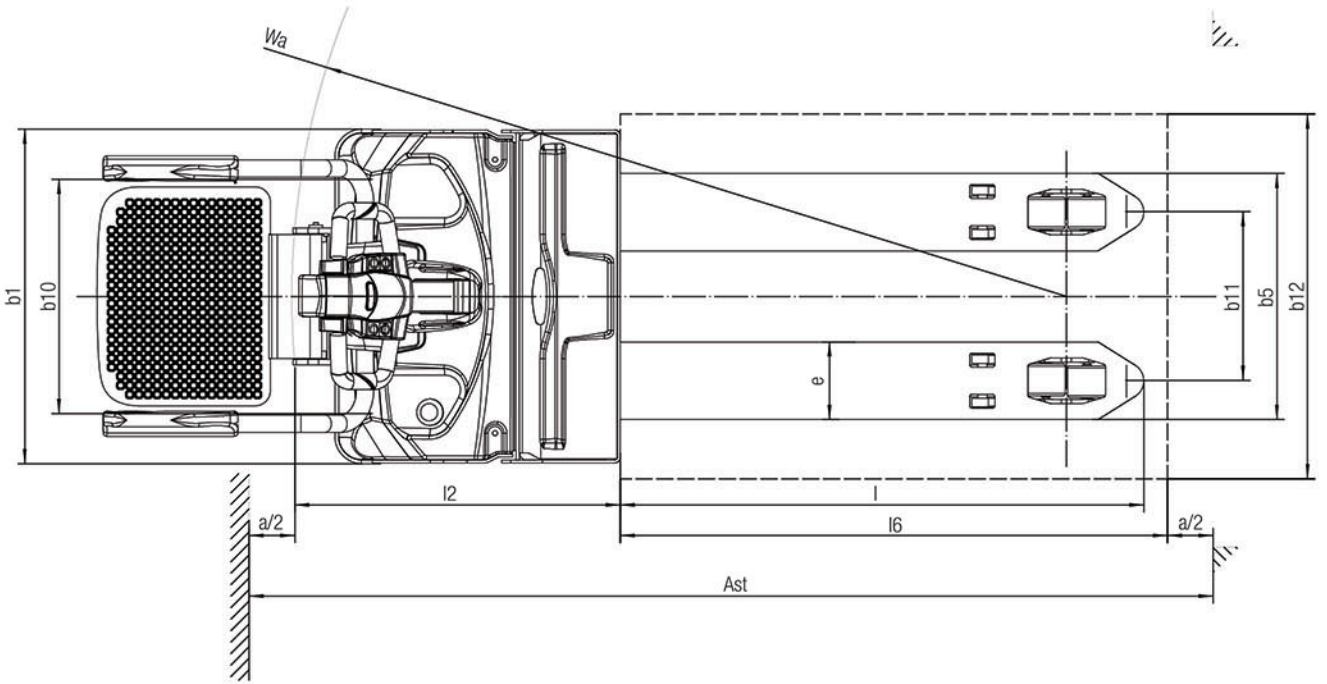
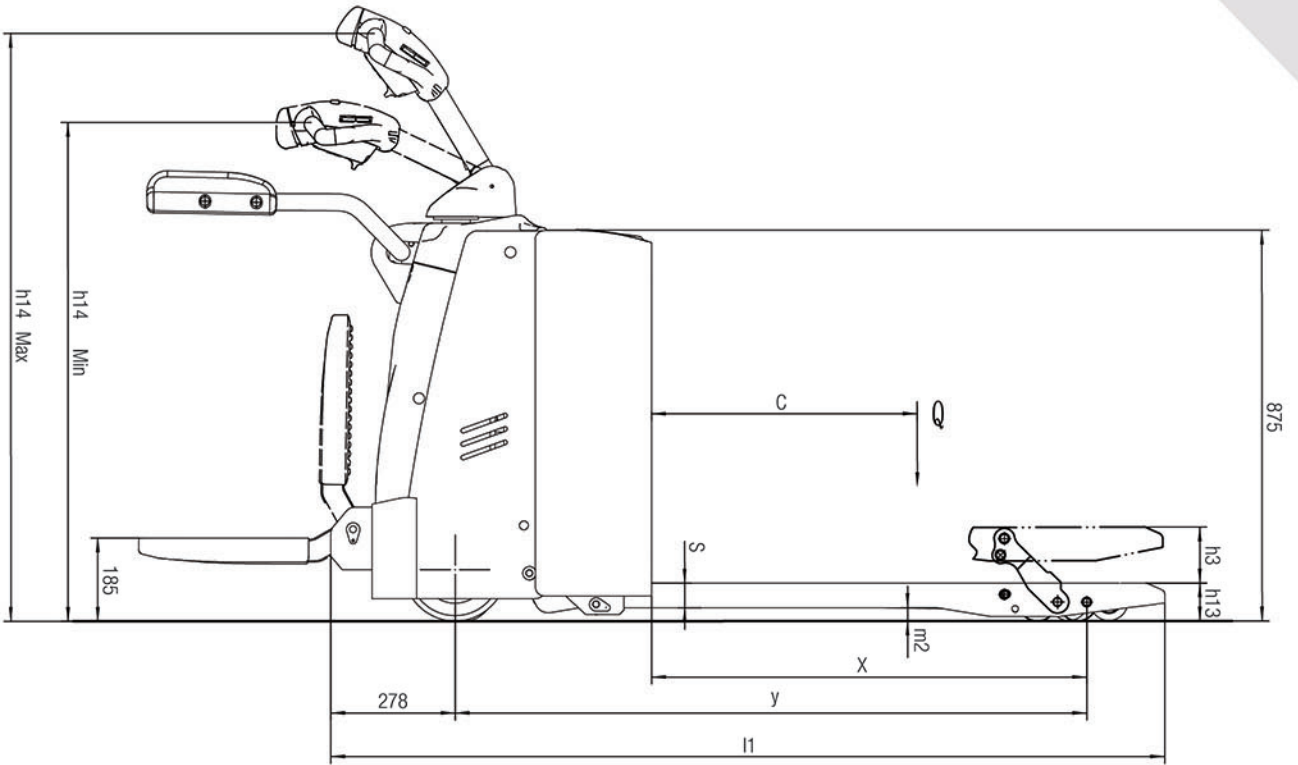

2020 by MLAP, All Rights Reserved.  
 All Trademarks are the property of their respective owners.  
 Printed in Singapore.  
 FML00012 (09/20)